

Keller

Oberdorfstrasse 34, 3072 Ostermündigen

Untergeschoss

Nettofläche: 31 m²

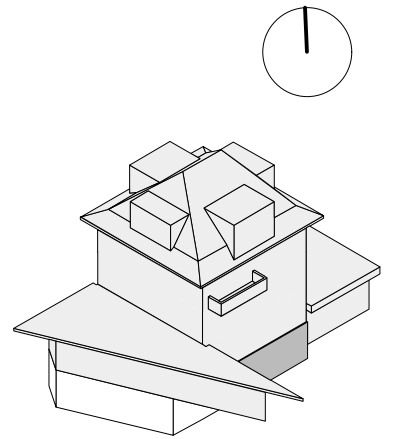

0 50 1.00 2.00 3.00 m

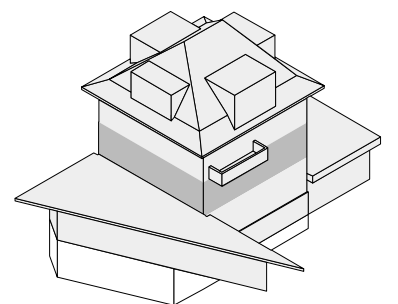
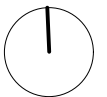
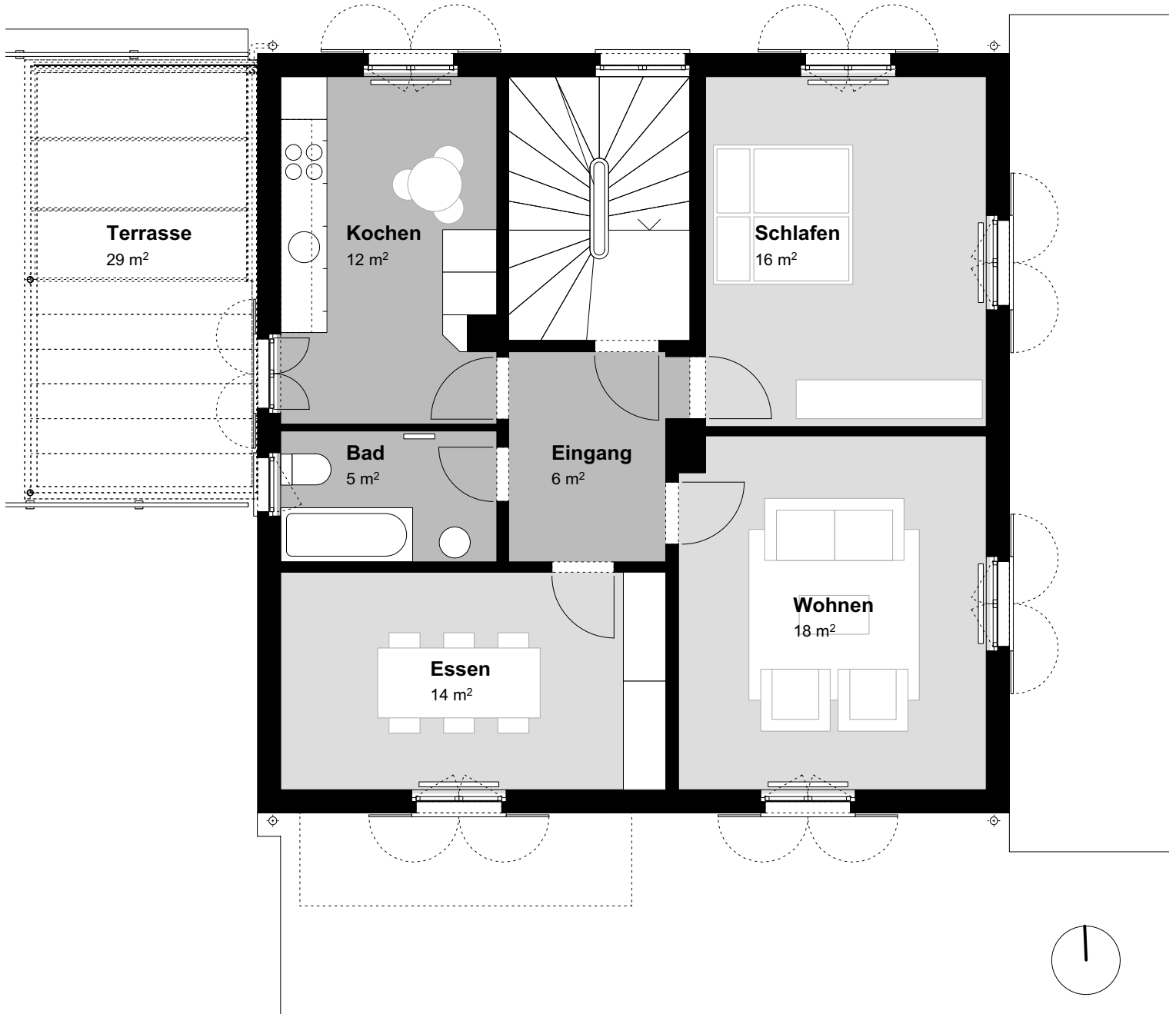

3-Zimmerwohnung

1. Obergeschoss

Oberdorfstrasse 34, 3072 Ostermündigen Nettowohnfläche: 72 m²



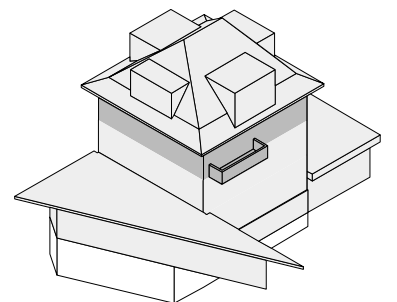
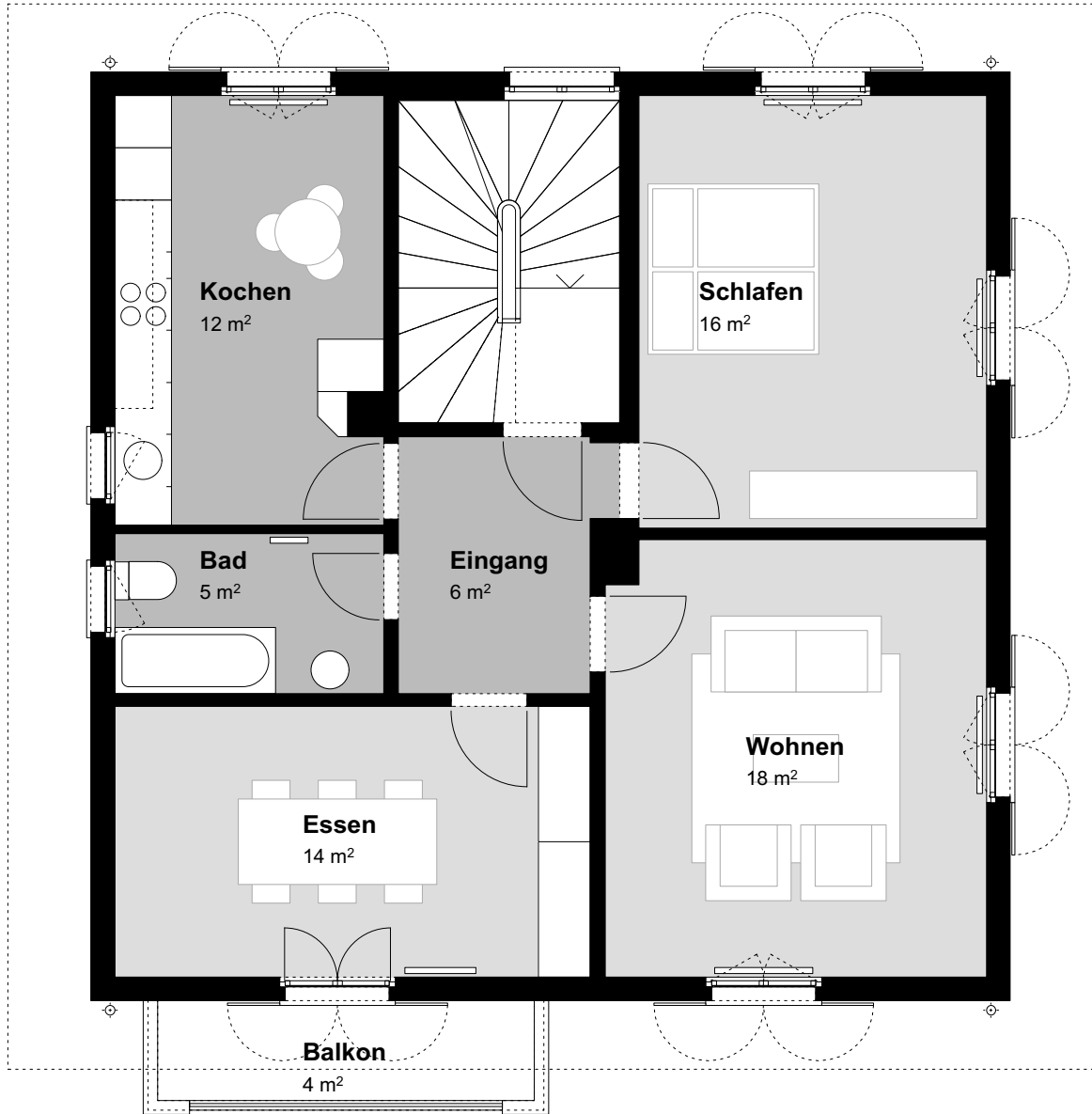

3-Zimmerwohnung

2. Obergeschoss

Oberdorfstrasse 34, 3072 Ostermündigen Nettowohnfläche: 72 m²

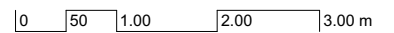

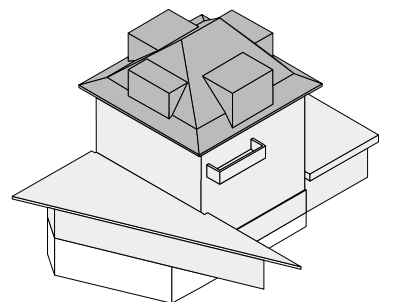
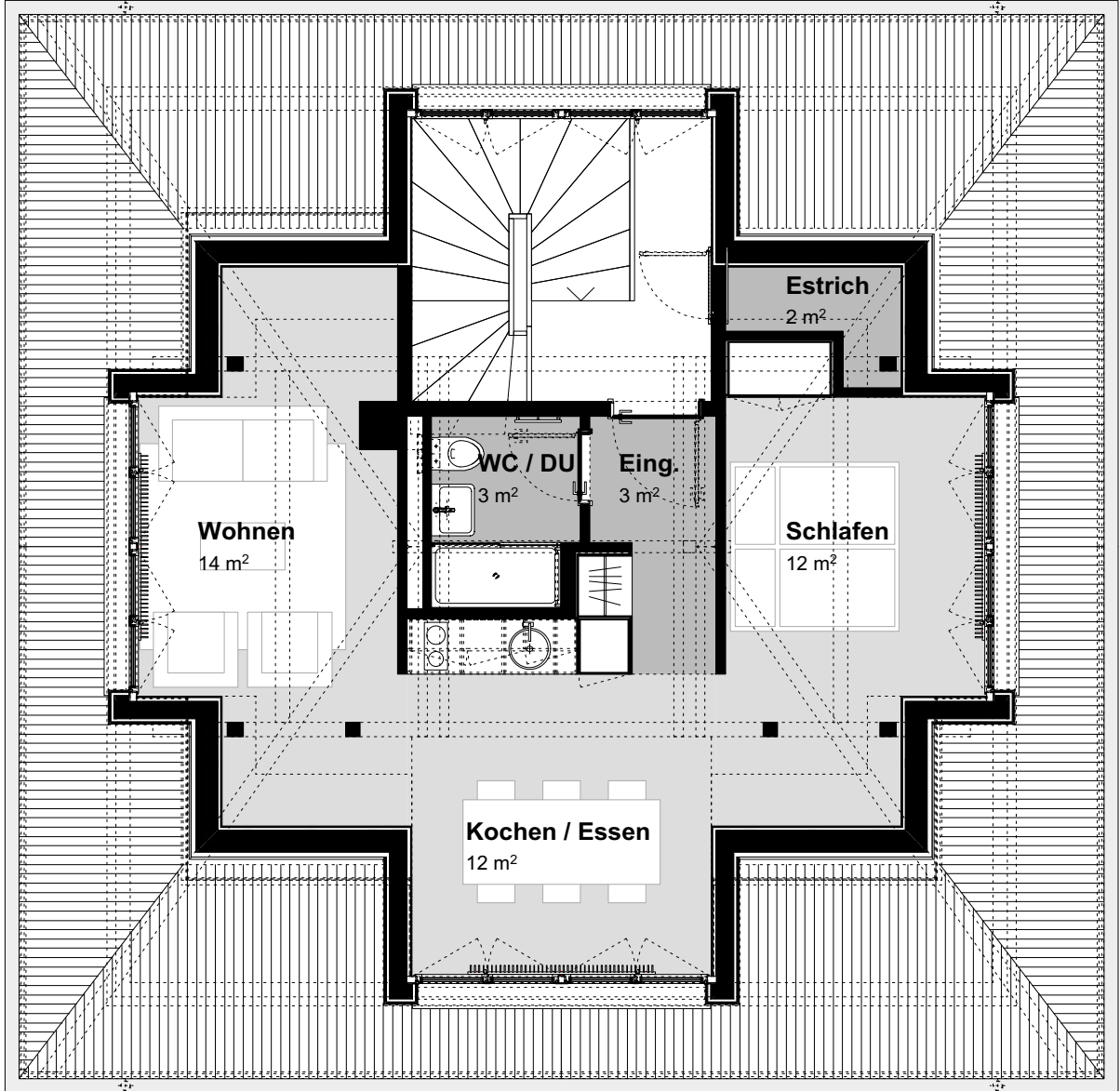

2½-Zimmerwohnung

Dachgeschoss

Oberdorfstrasse 34, 3072 Ostermündigen Nettowohnfläche: 45 m²

